

## CE106

## Ball and Beam Apparatus

**Compact, self-contained, bench-mounting apparatus to study basic and advanced principles of control, including control of naturally unstable systems**

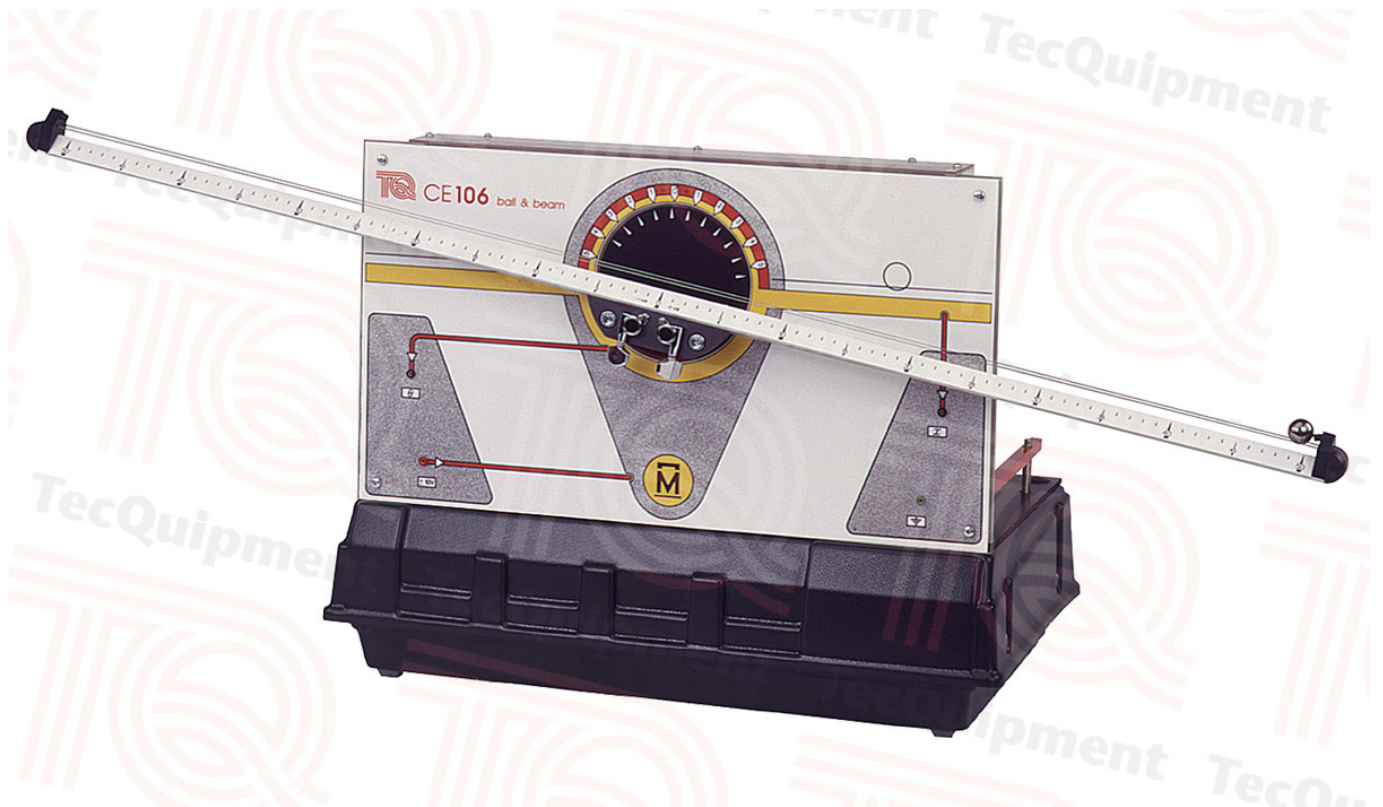

- Naturally unstable mechanical control system
- Self-contained, compact and bench-mounting unit
- Ideal for classroom demonstrations and student project work
- Highly visual apparatus, with moving ball and front panel mimic diagram of the process – students can clearly see what they are controlling
- All inputs and outputs buffered for connection to TecEquipment's optional controllers or other suitable controllers
- For basic and advanced experiments with angle, velocity and position control
- Mimics real control problems in unstable systems, such as missile or rocket take-off

# CE106

## Ball and Beam Apparatus

### Description

The Ball and Beam Apparatus shows the control problems of unstable systems, for example a rocket or missile during launch, which needs active control to prevent the missile going unstable and toppling over.

The apparatus has a steel ball which is free to roll on two parallel tensioned wires. The wires are on a beam that pivots at its centre. A servo motor controls the beam angle and sensors measure the beam angle and ball position. The basic control problem is to vary the beam angle to control the ball position. The system is a double integrator, so it is naturally unstable. It needs active feedback control using phase-advance methods.

The CE106 comes with a user guide which includes full details of how to use the equipment and typical experiments.

It also includes a set of cables and connectors for connection to other equipment. All control connections work with 0 to 10 VDC signals.

**Note:** You must use the CE106 with TecEquipment's optional CE120 Controller, the optional CE122 Digital Interface or other suitable controllers with 10 V inputs and outputs. Details of the CE120 and CE122 are on separate datasheets.

The CE106 includes a set of cables and connectors for connection to other equipment.

All control connections work with 0 to 10 VDC signals.

### Standard Features

- Supplied with comprehensive user guide
- Two-year warranty
- Made in accordance with the latest European Union directives

### Experiments

- Measurement of system dynamics by transient and closed-loop methods
- Design of analogue phase-advance compensators
- Design of state reconstructors to obtain estimates of ball velocity and position

The flexible design of the equipment allows the user to develop many other analysis and control exercises to suit their needs. It is good for extended or advanced control experiments, and is ideal for student project work.

### Essential Ancillaries

- Controller (CE120) – A controller with analogue and digital controls and instruments
  - or**
  - Digital Interface (CE122) – An interface which connects between most products in the Control Engineering range and a suitable computer (not included)
  - or**
  - Other suitable controller with 10 V inputs and outputs
- Both the CE120 and the CE122 include TecEquipment's CE2000 Control Software with editable, pre-made control experiments for use with the CE106.

### Essential Services

*Electrical supply:*

240/110 VAC, 1 A, 50/60 Hz, with earth

Other voltages and frequencies available to special order

*Bench space needed:*

1.5 m x 750 mm

### Operating Conditions

*Operating environment:*

Laboratory environment

*Storage temperature range:*

-25°C to +55°C (when packed for transport)

*Operating temperature range:*

+5°C to +40°C

*Operating relative humidity range:*

80% at temperatures < 31°C decreasing linearly to 50% at 40°C

### Sound Levels

Less than 70 dB(A)

### Specifications

*Nett dimensions and weight:*

1070 mm x 330 x 420 mm, 18 kg

*Packed dimension and weight:*

0.64 m<sup>3</sup>, 52 kg (approx – packed for export)

*Input: 0 to 10 VDC*

- Motor

*Outputs: 0 to +/- 10 VDC*

- Ball position
- Beam angle