

PS110

Transformer Trainer

Investigates the principles and operating characteristics of single-phase and three-phase power and distribution transformers

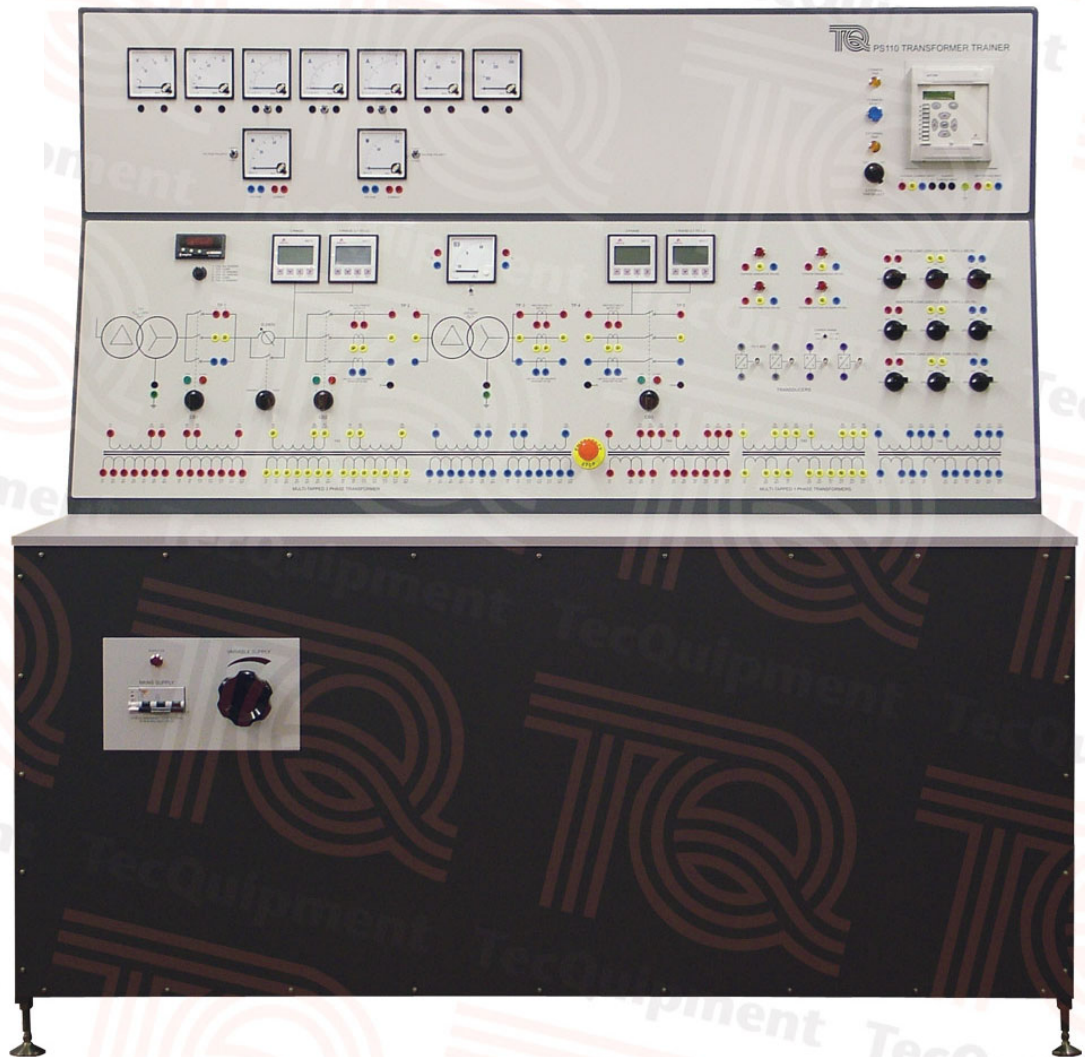

- Self-contained teaching module, ideal for class and project work
- Part of TecEquipment's Modular Power System – can connect to other parts of the system for even more experiments
- Includes educational transformers with fully accessible and unique one-volt-per-turn primary, secondary and tertiary windings
- Built-in industrial-standard digital protection relay gives wide range of functions – module also includes an extra socket for additional relays to give more experiments
- Separate single and three-phase educational transformers, with an additional delta-star transformer
- Detailed mimic diagram and clear labelling to help students' understanding
- Includes supplies, circuit protection, internal load banks, instruments and controls
- Thermocouples included in transformer windings for thermal tests

- TecEquipment Ltd, Bonsall Street, Long Eaton, Nottingham NG10 2AN, UK
- **T** +44 115 972 2611 • **F** +44 115 973 1520 • **E** info@tecquipment.com • **W** www.tecquipment.com
- An ISO 9001 certified company

PS110

Transformer Trainer

Description

Part of the Modular Power System range, the Transformer Trainer module fully examines single-phase and three-phase power and distribution transformers.

The fully instrumented unit includes:

- One three-phase educational transformer
- Three single-phase educational transformers with tertiary windings
- One three-phase delta-star transformer

All windings of the educational transformers connect to colour-coded shrouded sockets on the control panel. The educational transformers work at one volt each turn, so the no-load output voltages are the same as the number of secondary turns.

An adjustable autotransformer allows lower voltage experiments (for example - with the educational transformers). The module includes a second fixed ratio delta-star transformer for experiments. This transformer also works with the optional Salient Pole Generator (PS100), to allow experiments on three-phase supply to other loads (utilisation).

The control panel includes all the analogue and digital meters and transducers needed to measure electrical voltage, current and power for all transformer tests. Also included are selectable resistive, inductive and capacitive loads, which can connect in parallel, series, delta or star connection.

Thermocouples are fixed to one set of windings and core of the three-phase educational transformer. They are also fixed to one of the single-phase educational transformers. The thermocouples connect to a digital temperature indicator to provide direct readings of core and winding temperatures.

For protection tests, the three-phase circuits include current transformers to link to an industrial standard protection relay. The user connects and sets the protection relay to detect line and earth currents, voltage and frequency faults. The relay also monitors and measures fault events and disturbances for fault analysis. The user sets the relay from its local control panel or by a cable link to a suitable computer (computer not included) and software (included). When the user applies a circuit fault, the relay opens circuit-breakers in the test circuits. The circuit-breakers also include hand-operated switches, and lamps. The lamps show whether the circuit-breakers are open or closed.

An extra socket on the equipment supplies power and control for any optional relays (available separately) for use with the module, for example TecEquipment's Differential Protection Relay (PS252).

Supplied with the equipment is a set of shrouded leads for the user to connect the test circuits together. The unit includes an emergency switch, a mains supply isolator and protection fuses.

Standard Features

- Supplied with comprehensive user guide
- Two-year warranty
- Manufactured in accordance with the latest European Union directives

Experiments

Note: This unit can do an unlimited range of experiments. TecEquipment's manuals include several suggested experiments including:

- Voltage and turns ratios
- Parallel and series windings, delta, star and interstar
- Open and short circuit tests to find transformer properties, including losses and efficiency
- Balanced and unbalanced loads
- Phase differences in popular three phase transformer connections
- Three to two-phase connections (Scott and Le Blanc)

Other Possible Experiments (not detailed in TecEquipment's manuals)

- Core and winding temperatures in a three phase transformer (thermal tests)
- The effect of core-type construction in a three-phase transformer
- The effect of abnormal voltages and frequency, when used with the Salient Pole Generator (PS100)
- Differential protection of a delta-star connected transformer, when used with the Differential Protection Relay (PS252)

Recommended Ancillaries

Additional relays:

- Differential Protection Relay (PS252)

Oscilloscope:

Two Channel Digital Storage Oscilloscope (OS2)

Other Modular Power System units:

One or more of the other parts of the Modular Power System, that includes:

- Salient Pole Generator (PS100)
- Transmission Line Simulator (PS120)
- Distribution Trainer (PS130)
- Switched Busbar Module (PS150)

Also, to help connect two or more parts of the Modular Power System, TecEquipment recommends that you use the Modular Power System Hub (PS160).

- TecEquipment Ltd, Bonsall Street, Long Eaton, Nottingham NG10 2AN, UK
- **T** +44 115 972 2611 • **F** +44 115 973 1520 • **E** info@tecquipment.com • **W** www.tecquipment.com
- An ISO 9001 certified company

PS110

Transformer Trainer

The Modular Power System

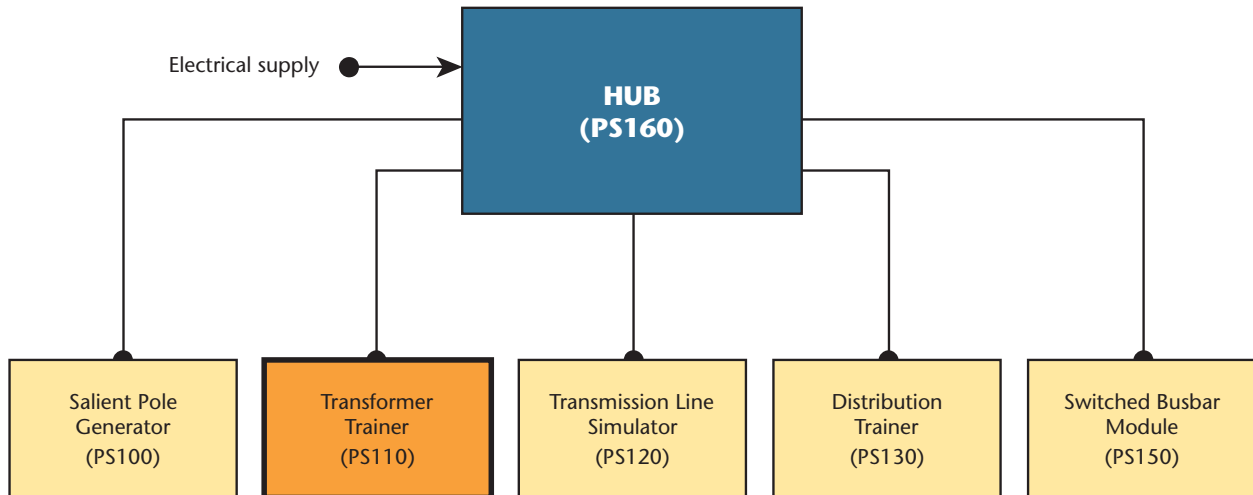

Essential Services

The module can connect directly to an electrical supply as a stand-alone unit, or it can be powered from the optional PS160 Hub.

Electrical supply (stand-alone):

Three-phase 5 kVA, 50 Hz or 60 Hz (specify on order)

50 Hz needs 380/415 VAC at 16A

60 Hz needs 208/220 VAC at 32 A

Floor space needed:

Approximately 3 m x 2 m of solid, level floor

Operating Conditions

Operating environment:

Laboratory environment

Storage temperature range:

-25°C to +55°C (when packed for transport)

Operating temperature range:

+5°C to +40°C

Operating relative humidity range:

80% at temperatures < 31°C decreasing linearly to 50% at 40°C

Sound Levels

Less than 70 dB(A)

Specifications

Nett dimensions:

1850 mm x 1870 mm x 960 mm

Nett weight:

790 kg

Packed weight:

950 kg

Packed volume:

5 m³

Delta-star Transformer:

5 kVA 220/220 VAC three-phase delta to star (Dy11)

Single-phase educational transformers:

Three x one volt per turn transformers rated at 1 kVA and 240 V with multi-tapped primary, secondary and tertiary windings. One transformer has thermocouples to its windings and core.

Three-phase educational transformers:

Three x one volt per turn transformers rated at 1 kVA (total 3 kVA) and 240 V on a common three-phase core, with multi-tapped primary and secondary windings. One transformer has thermocouples to its windings and core.

- TecEquipment Ltd, Bonsall Street, Long Eaton, Nottingham NG10 2AN, UK
- **T** +44 115 972 2611 • **F** +44 115 973 1520 • **E** info@tecquipment.com • **W** www.tecquipment.com
- An ISO 9001 certified company