



## ≡ SUBSONIC WIND TUNNEL 305 MM STARTER SET

**VDAS®** AF1300S

A starter set consisting of the Subsonic Wind Tunnel 305 mm (AF1300), Basic Lift and Drag Balance (AF1300z) and a set of Three-Dimensional Drag Models (AF1300j).



### KEY FEATURES

- A wind tunnel for conducting experiments in aerodynamics
- Safe, compact, open-circuit suction wind tunnel – saves time and money compared to full-scale units
- Includes a lift and drag balance with a set of three-dimensional models for experiments in aerodynamic drag
- The balance works with TecEquipment's Versatile Data Acquisition System (VDAS®)
- Additional models and instruments available to extend the range of experiments
- Wind tunnel controls mount on a separate, free-standing instrument frame for ease of use
- The wind tunnel has wheels for easy mobility



# ≡ SUBSONIC WIND TUNNEL 305 MM STARTER SET

**VDAS**® AF1300S

## DESCRIPTION

Air enters the tunnel through an aerodynamically designed effuser (cone) that accelerates the air linearly. It then enters the working section and passes through a grill before moving through a diffuser and then to a variable-speed axial fan. The grill protects the fan from damage by loose objects. The air leaves the fan, passes through a silencer unit and then back out to atmosphere.

A separate control and instrumentation unit controls the speed of the axial fan (and the air velocity in the working section). The control and instrumentation unit also includes manometers and electrical outlets to supply electrical power to other optional instruments.

A metal frame supports the wind tunnel. The frame includes lockable castors for convenient mobility.

## WORKING SECTION

The working section of the tunnel is a square section with a clear roof, sides and floor. The sides are removable. The floor and each side panel has a special position to support the optional wind tunnel models. Supplied with the wind tunnel are a protractor and a model holder to support and accurately adjust the angle of any models fitted.

Two traversing probes fit on the working section. One is a Pitot-static tube and the other a standard Pitot tube. They fit upstream and downstream of any models and connect to the manometers of the instrumentation unit (or other optional instruments) to show pressure.

## INCLUDED WITH THE WIND TUNNEL

### BASIC LIFT AND DRAG BALANCE (AF1300Z)

This balance holds the models in the working section and measures the lift and drag forces on the models, created by the air moving past them.

### THREE-DIMENSIONAL DRAG MODELS (AF1300J)

A set of models, each with a different shape but the same frontal area for direct comparisons.

## INCLUDED ANCILLARIES DETAILS

### BASIC LIFT AND DRAG BALANCE (AF1300Z)



This simple to fit balance mounts onto the side of the wind tunnel working section. The balance works with both the supplied and other optional models.

It includes a digital display unit to show the forces. The display unit can connect to TecQuipment's VDAS® to log experiment data on a suitable computer (not supplied).

### THREE-DIMENSIONAL DRAG MODELS (AF1300J)



These models fit into the working section. They are held by the balance and allow students to see how shape affects aerodynamic drag. The models include 'classic' aerodynamic test shapes including a smooth sphere, a dimpled sphere and a streamline shape.

### MODEL HOLDER

The model holder is supplied to hold a model if the balance is not used. It is designed to hold a shaft of diameter  $11.95 \pm 0.015$  mm (diameter) and  $215 \pm 1.25$  mm (length) mounting stem.



### PROTRACTOR

The protractor fits on to the shaft of a model when the balance is not being used. It can be used when setting up models and rotating them during experiments.



# ≡ SUBSONIC WIND TUNNEL 305 MM STARTER SET

**VDAS**® AF1300S

## OPTIONAL ANCILLARIES DETAILS

### MULTITUBE MANOMETER (AFAI)

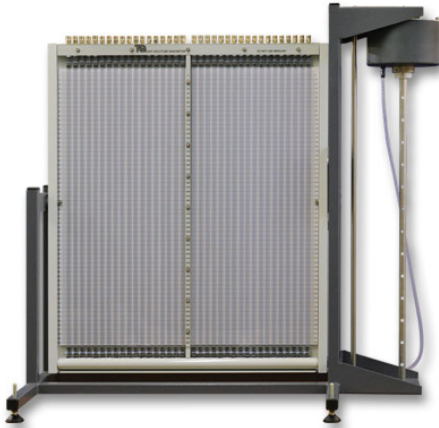

A 36-tube tilting manometer for measuring pressure in subsonic wind tunnels, including TecQuipment's AF1300. A backboard with a graduated scale holds each manometer tube.

For safety and convenience the manometer uses water as the manometer fluid. This is via an adjustable reservoir with a fine-adjust handwheel held at the side of the equipment. Water colouring is included to aid visibility.

The top of each manometer tube has a connection piece for tubing to connect to pressure tapings on the equipment being monitored. The whole manometer tube assembly is mounted on a swivel. This allows it to be tilted in preset increments to increase the sensitivity of measurement. Adjustable feet enable the whole apparatus to be precisely levelled before use.

The manometer is supplied with operating instructions, a filling funnel and a spirit level.

### THREE COMPONENT BALANCE (AF1300T)

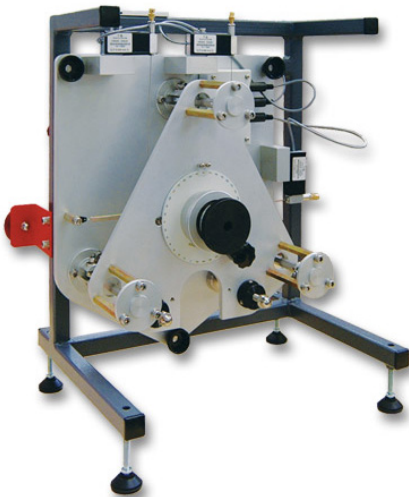

The Three-Component Balance fits onto the working section of TecQuipment's Subsonic Wind Tunnel (AF1300).

The Three-Component Balance provides an easy-to-use support system for wind tunnel models. It measures lift, drag and pitching moment exerted on the model.

The balance comprises a mounting plate secured to the wind tunnel working section. A triangular force plate is held on the mounting plate by a mechanism that constrains it to move in a plane parallel to the mounting plate only, while leaving it free to rotate about a horizontal axis. This arrangement provides the necessary three degrees of freedom.

Models for use with the balance are available from TecQuipment. Other models used with the equipment will need a mounting stem. The forces acting on the model are transmitted by cables to three strain gauged load cells. The output from each load cell is taken via an amplifier to a display module. The display module mounts onto the wind tunnel control and instrumentation frame and includes a digital display to show the lift, drag and pitching moment directly.

The equipment is fully compatible with TecQuipment's Versatile Data Acquisition System (VDAS®) and can quickly and conveniently connect to the frame-mounted interface unit (VDAS-F).

The model support of the balance can be rotated by 360 degrees. This allows adjustment of the angle of incidence of the model to the direction of air flow. The model support is locked in the required position by a simple clamp after adjustment.

### BALANCE ANGLE FEEDBACK UNIT (AFA4)

The Balance Angle Feedback Unit is for use with the Three-Component Balance (see above) to measure the angular position of models mounted on the balance in the wind tunnel.

The Angle Feedback Unit mounts on the Three-Component Balance attached to the wind tunnel. It then transmits the rotational angle of the model to (VDAS®). The angle of the model is logged on a suitable computer along with the other captured experimental data.

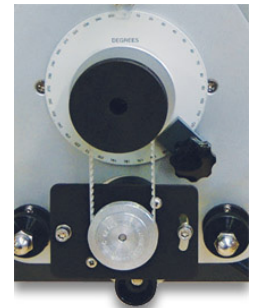

# ≡ SUBSONIC WIND TUNNEL 305 MM STARTER SET

**VDAS® AF1300S**

## DIFFERENTIAL PRESSURE UNIT (AFA5)

The Differential Pressure Transducer and readout is an optional ancillary to TecQuipment's Subsonic Wind Tunnel (AF1300). It measures and displays pressures in Pitot-static tubes and other pressure-sensing devices fitted to a wind tunnel, with respect to the atmosphere or differential pressures.



The control and instrumentation panel of the AF1300 wind tunnel includes a location for mounting up to two Differential Pressure Transducer modules. Each module contains a calibrated pressure transducer. The unit has an integral liquid crystal display that allows the user to read pressure directly.

The signals of the pressure sensors may be output to TecQuipment's optional Versatile Data Acquisition System.

When the Differential Pressure Transducer is used with the automatic data acquisition unit it provides a significant advantage over conventional instruments such as manometers. Many readings can be taken and the user may use a suitable spreadsheet software package to obtain a more accurate overview of pressure distributions.

## 32-WAY PRESSURE DISPLAY UNIT (AFA6)

The 32-Way Pressure Display Unit measures and displays up to 32 different pressures from models, Pitot-static tubes and other measuring instruments fitted to a wind tunnel. It is ideally suited in applications where multiple pressure measurements are required, for example in boundary layer and tapped aerofoil model investigations.



The unit mounts onto the control and instrumentation frame of the AF1300 wind tunnel. The unit contains 32 calibrated pressure transducers. Input connection to each is via quick-release pressure inputs mounted on the front panel of the unit. This allows easy and quick connection between the unit and an experiment mounted in a wind tunnel. All pressures are measured with respect to atmosphere. The unit has an integral liquid crystal display with a scroll switch that allows all 32 channels to be viewed in groups of four at any time.

The conditioned outputs of the pressure sensors may be output to TecQuipment's Versatile Data Acquisition System (VDAS®).

When the 32-Way Pressure Display Unit is used with the system it allows laboratory time to be used more efficiently

because data can be captured and processed much more quickly than when using manual techniques. The facility in the software to average data to remove the fluctuations inherent in wind tunnel measurements, enhances the quality of the results by making their interpretation much easier. This option provides significant experimental advantages over conventional instruments such as manometers.

## PITOT STATIC TRAVERSE (AFA7)



A Pitot-static tube that mount in the working section of the wind tunnel, either upstream of the position of the test model or on the fore-aft traverse. This allows students to do 'wake' traverses, of a model. The vertical position of the tube, which is adjustable, is displayed on a digital indicator.

The digital indicator position can be set to zero in any position. This allows the datum or starting point of an experiment to be defined by the user.

To display differential pressure, each Pitot-static tube connects to the Tilting Multi-Tube Manometer (AFA1) (supplied as an optional extra).

Alternatively, pressures can be measured using one or more of the following instruments:

- Differential Pressure Unit (AFA5)
- 32-Way Pressure Display Unit (AFA6)

The position of the Pitot-static Traverse may be output to VDAS® to allow computer-based data acquisition and display.

## SMOKE GENERATOR (AFA11)



The smoke generator and probe is an optional ancillary to allow the observation of airflow in subsonic wind tunnels and other airflow situations.

# ≡ SUBSONIC WIND TUNNEL 305 MM STARTER SET

**VDAS® AF1300S**

## VERSATILE DATA ACQUISITION SYSTEM (VDAS-F)

TecQuipment's modern, cost-effective and accurate Versatile Data Acquisition System (VDAS®) improves laboratory teaching. It works with a growing list of over 50 TecQuipment products, enabling real-time display and capture of experiment data.

For both individual student use or for lecturers demonstrating experiments to a whole class, VDAS® gives real-time calculation, recording and charting with fast data export. This makes efficient, productive and effective use of time for both students and lecturers.

The digital inputs on the interface connect directly to the instrumentation on suitable TecQuipment products. These inputs are non-specific, for easy experiment setup and reduced connection errors. The mostly digital communications circuits make the equipment more resistant to electrical noise than purely analogue systems.

The interface units also have two analogue inputs. These are for fast-moving (transient) signals from some TecQuipment products or for transducers and sensors. These may include displacement or pressure measuring sensors and flow meters. VDAS® can display the analogue signals in real-time as traces on a computer screen. This allows VDAS® to work as a user-friendly alternative to an oscilloscope on selected products.

The output from the interface unit connects to a computer (not supplied) running the VDAS® software. The software has extra features that allow the addition of derivative traces and reference traces, based on each of the two analogue input signals. It is possible to adjust software filtering and smoothing of each signal trace, and scale the traces to best fit the trace area.

The software is intuitive and easy to use, with clear and convenient data display options. The software looks similar and works in a similar way for each TecQuipment VDAS® compliant product. This saves time as students do not have to learn to use new software when changing experiments.



## LEARNING OUTCOMES

This Starter Set includes parts for experiments in three-dimensional drag due to different body shapes and surface dimples.

### ADDITIONAL EXPERIMENTS:

TecQuipment can also supply other optional models and instruments to extend experiments, giving:

- Flow past bluff and streamlined bodies with pressure and velocity observations in the wake
- Investigations into boundary layer development
- Influence of aspect ratio on aerofoil performance
- Performance of an aerofoil with flap, influence of flap angle on lift, drag and stall
- Pressure distribution around a cylinder under sub-critical flow conditions
- Study of characteristics of models involving basic measurement of lift and drag forces
- Study of the characteristics of three-dimensional aerofoils involving measurement of lift, drag and pitching moment
- Study of the pressure distribution around an aerofoil model to derive the lift and comparison with direct measurements of lift
- Flow visualisation

## STANDARD FEATURES

- Supplied with a comprehensive user guide or guides(s)
- Five-year warranty
- Manufactured in accordance with the latest European Union directives
- An ISO 9001 certified company

# ≡ SUBSONIC WIND TUNNEL 305 MM STARTER SET

**VDAS® AF1300S**

## ANCILLARIES

### MINIMUM INSTRUMENTS REQUIRED

It is possible to complete all AF1300 experiments without using VDAS®. However there is a minimum additional instrumentation requirement for some experiments.

All TecQuipment electronic instruments e.g. the 32-Way Pressure Display Unit (AFA6) have visual displays from which data can be transcribed.

Other instruments e.g. the Multitube Manometer (AFA1) are read manually and the data transcribed.

**NOTE:** AF1300s is supplied with the Basic Lift and Drag Balance, a standard Pitot tube, a Pitot-static tube and a manometer (built in to the control panel). Some or all of these instruments will be required in addition to the optional instruments listed here to complete the experiments.

It is, however, possible to utilise the first five models without any additional instrumentation (the Three Dimensional Drag Models are included AF1300j).

<b>MINIMUM INSTRUMENTATION REQUIRED IF NOT USING VDAS®</b>	Basic Lift and Drag Balance (AF1300Z) <b>OR</b> Three Component Balance (AF1300T)	Three Component Balance (AF1300T)	Multi Tube Manometer (AFA1)
Cylinder Model (AF1300a)	✓		
Set of Two NACA 0012 Aerofoils (AF1300d)	✓		
Flat Plate Drag Model (AF1300e)	✓		
Three Dimensional Drag Models (AF1300j)	✓		
S1210 Aerofoil (AF1300l)	✓		
NACA 0012 Aerofoil with Tappings (AF1300b)			✓
Boundary Layer Model (AF1300f)			✓
NACA 2412 Aerofoil with Flap (AF1300c)		✓	
Aircraft Model - Low Wing (AF1300g)		✓	
Aircraft Model - High Wing (AF1300h)		✓	
Winglets and End Plates (AF1300q)		✓	
Flutter Wing (AF1300r)	No instruments required		

<b>INSTRUMENTATION REQUIRED IF USING VDAS®</b>	Differential Pressure Transducer (AFA5)	<b>EITHER</b> Basic Lift and Drag Balance (AF1300Z) <b>OR</b> Three-Component Balance (AF1300T) <b>WITH</b> Angle Feedback Unit (AFA4)	Pitot-static Traverse (AFA7)	32-Way pressure Display Unit (AFA6)	Three Component Balance (AF1300T) <b>WITH</b> Angle Feedback (AFA4)
Cylinder Model (AF1300a)	2	✓	✓		
Set of Two NACA 0012 Aerofoils (AF1300d)	2	✓	✓		
Flat Plate Drag Model (AF1300e)	2	✓	✓		
Three Dimensional Drag Models (AF1300j)	2	✓	✓		
S1210 Aerofoil (AF1300l)	2	✓	✓		
NACA 0012 Aerofoil with Tappings (AF1300b)	2		✓	✓	
Boundary Layer Model (AF1300f)	✓			✓	
NACA 2412 Aerofoil with Flap (AF1300c)	✓		✓		✓
Aircraft Model - Low Wing (AF1300g)	✓		✓		✓
Aircraft Model - High Wing (AF1300h)	✓		✓		✓
Winglets and End Plates (AF1300q)	✓				✓
Flutter Wing (AF1300r)	✓				



# ≡ SUBSONIC WIND TUNNEL 305 MM STARTER SET

**VDAS**® AF1300S

## INCLUDED ANCILLIARIES

- Basic Lift and Drag Balance (AF1300z)

## INCLUDED EXPERIMENTS:

- Three-dimensional Drag Models (AF1300j)

## RECOMMENDED ANCILLARIES

- Multi-Tube Manometer (AFA1)
- Three-Component Balance (AF1300t)
- Angle Feedback Unit (AFA4)
- Differential Pressure Transducer (AFA5)
- 32-Way Pressure Display Unit (AFA6)
- Pitot-Static Traverse (300 mm) (AFA7)
- Smoke Generator (AFA11)
- Versatile Data Acquisition System (VDAS-F)

## RECOMMENDED EXPERIMENTS:

- Cylinder Model (AF1300a)
- NACA 0012 Aerofoil with Tappings (AF1300b)
- NACA 2412 Aerofoil with Flap (AF1300c)
- Set of Two NACA 0012 Aerofoils (AF1300d)
- Flat Plate Drag Model (AF1300e)
- Boundary Layer Model (AF1300f)
- Aircraft Model - Low Wing (AF1300g)
- Aircraft Model - High Wing (AF1300h)
- S1210 Aerofoil (AF1300l)
- Winglets and End Plates (AF1300q)
- Flutter Wing (AF1300r)

## THE PRODUCT SHIPS IN ITS STOWED STATE

See below for dimensions:

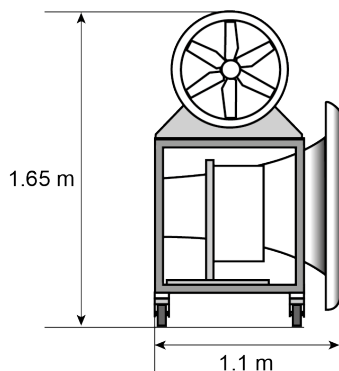

## OPERATING CONDITIONS

### OPERATING ENVIRONMENT:

Laboratory

### STORAGE TEMPERATURE RANGE:

-25°C to +55°C (when packed for transport)

### OPERATING TEMPERATURE RANGE:

+5°C to +40°C

### OPERATING RELATIVE HUMIDITY RANGE:

80% at temperatures < 31°C decreasing linearly to 50% at 40°C

## SPECIFICATION - WIND TUNNEL (AF1300)

TecEquipment is committed to a programme of continuous improvement; hence we reserve the right to alter the design and product specification without prior notice.

### NETT DIMENSIONS AND WEIGHT (ASSEMBLED):

3700 mm x 1065 mm x height 1900 mm and 293 kg

### APPROXIMATE PACKED VOLUME AND WEIGHT:

4.9 m<sup>3</sup> and 450 kg

### SPACE NEEDED:

Solid, level floor – allow at least 2 m of free space around the inlet and 4 m at the outlet

### WORKING SECTION:

305 mm x 305 mm, and 600 mm long.

Air velocity: 0 to 36 m.s<sup>-1</sup>

### NOISE LEVELS:

80 dB(A) at operators ear level.

### ELECTRICAL SUPPLY (THREE PHASE):

220 VAC to 240 VAC 50 Hz/60 Hz (20 A) or

380 VAC to 440 VAC 50 Hz/60 Hz (16 A)

## ANCILLARY AND EXPERIMENT SPECIFICATIONS

For specifications of included and optional ancillaries and experiments please see their individual data sheets.

