

VDAS® SMI005

EULER BUCKLING APPARATUS

Bench-top apparatus tests different types of strut and demonstrates how they deflect under load, and demonstrates the use of Southwell's method.

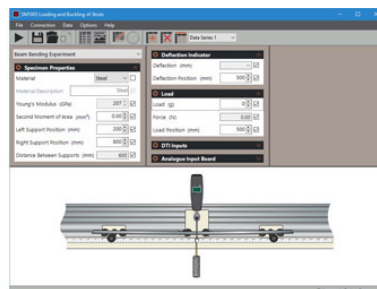

SCREENSHOT OF THE
OPTIONAL VDAS®
SOFTWARE



KEY FEATURES

- Full analysis of buckling (crippling) of struts
- Can also test struts as simply supported beams – to extend experiments and find flexural rigidity of the struts
- Buckling tests cover pinned and clamped (encasté) ends for various strut lengths and cross sections
- Special end fittings allow tests with eccentric loading
- Electronic load cell and digital display for accurate measurement of end load
- Digital dial gauge measures lateral deflection at any point along a strut
- Range of ten struts supplied as standard
- Extra specimen struts available for more advanced experiments



EULER BUCKLING APPARATUS

DESCRIPTION

The SM1005 Loading and Buckling of Struts allows tests on a full range of struts. It shows load and deflection characteristics and buckling loads for various strut lengths, cross-section and end conditions. It also allows studies of the effect of eccentric loading.

An optional set of extra specimens (SM1005a) allows extra tests to show students some of the more complicated problems found in strut design.

The main part of the apparatus is a precision-engineered rigid aluminium base, with legs and levelling feet. At one end is a loading device which uses a screw to apply loads to the struts. The screw is in fixing blocks with bearings to give precise and easy load application.

At the opposite end is the load measuring device. This is a precision mechanism that resists the bending moments produced by the struts as they deflect, and transmits the pure axial force to an electronic load cell. This gives an accurate measurement of buckling load. A digital load meter (DL1 – included) shows the load.

Students may move the load-measuring device along the base to work with struts of different lengths and fixing conditions.

A digital dial indicator fixed to a movable slide measures the deflected shapes of the struts. A scale shows the position of the indicator. The digital load meter and the digital dial indicator can connect to TecQuipment's optional VDAS® (Versatile Data Acquisition System).

Holders are at both the loading and load measuring ends. They allow students to create any combination of 'pinned' or clamped end conditions for the strut under test. Supplied is a set of special end fittings for tests with various eccentricities to show the effect of eccentric loading.

The equipment includes a lateral pull attachment for students to apply light biasing loads, or larger side loads, as needed.

Students can also set up the apparatus to examine flexural rigidity and general beam deflection theory.

The standard set of ten struts (supplied) covers the primary variables of length, cross-section and end conditions.

The optional set of additional struts (SM1005A) includes struts of different materials, typical engineering sections, and two special struts. The two special struts show how buckling loads may be lower than the ideal values, because of two reasons:

- Flexure of the end fixings
- Imperfect shearing connections between the parts of a compound strut

For quick and reliable tests, TecQuipment can supply the optional VDAS® (Versatile Data Acquisition System). VDAS® gives accurate real-time data capture, monitoring and display, calculation and charting of all important readings on a computer. The computer is not supplied.

LEARNING OUTCOMES

WITH THE STANDARD SET OF TEN SPECIMENS:

- Demonstration of buckled (crippled) shape of struts with different end conditions.
- Determination of load/deflection curves and buckling loads for struts of different lengths and cross-sections, with any combination of 'pinned' or clamped end fixings.
- Comparing experiment results with those using Euler's buckling theory
- Investigation of the effects of side load and eccentric loading on strut buckling characteristics.
- Flexural rigidity and buckling loads for struts of different materials.
- The use of Southwell's method to estimate buckling loads and strut eccentricities from experimental results.
- Determination of flexural rigidity and comparison with calculated values.
- Deflections of a simply supported beam with a point load including the verification of general deflection formulae, and the deflected shape.

WITH THE SM1005A OPTIONAL SET OF ADDITIONAL STRUTS:

- Flexural rigidity and buckling loads for struts of a further range of different materials.
- Tests on typical engineering sections (circular, angle, channel and irregular section specimens); the significance of the neutral axes; combined bending and twisting due to eccentric loading.
- The effect of flexibility in end fixings.
- Tests on a compound strut with imperfect shearing connections between the two components.

STANDARD FEATURES

- Supplied with comprehensive user guide
- Five-year warranty
- Manufactured in accordance with the latest European Union directives
- ISO9001 certified manufacturer

RECOMMENDED ANCILLARIES

- VDAS-B: a bench-mounted version of the Versatile Data Acquisition System
- SM1005a: Set of additional struts

EULER BUCKLING APPARATUS

SPECIFICATIONS

TecQuipment is committed to a programme of continuous improvement; hence we reserve the right to alter the design and product specification without prior notice.

SM1005

NETT DIMENSIONS AND WEIGHT OF MAIN PART:

1350 mm long x 500 mm wide x 500 mm high and 24 kg

NETT DIMENSIONS AND WEIGHT OF DIGITAL LOAD METER:

170 x 60 x 200 mm, 1.4 kg

NETT WEIGHT OF ADDITIONAL BEAMS AND OTHER ITEMS:

1 kg

PACKED DIMENSIONS AND WEIGHT OF COMPLETE PACKAGE:

Approximately 0.5 m³, 40 kg

LOADING DEVICE:

Screw with linear and thrust bearings

LOAD MEASURING DEVICE:

Electronic load cell, with digital readout of force (digital load meter) 0 to 2000 N capacity with output to VDAS®

DEFLECTION MEASUREMENT:

Digital indicator 0 to 25 mm in 0.01 increments, with output to VDAS®.

BIASING WEIGHTS:

1 x 10 g weight hanger and 50 x 10 g weights

SPECIMEN STRUTS (ALL NOMINAL SIZES):

- 6 off mild steel 20 x 3 mm, lengths 750, 700, 650, 625, 600, 550 mm
- 1 off mild steel 15 x 4 x 750 mm
- 1 off mild steel 10 x 5 x 750 mm
- 2 off 19 x 4.8 x 750 mm in brass and aluminium

SM1005A - SET OF TEN ADDITIONAL STRUTS

NETT DIMENSIONS AND WEIGHT:

800 x 310 x 15 mm, 2 kg

PACKED DIMENSIONS AND WEIGHT:

Approximately 0.024 m³, 3.5 kg

STRUTS (APPROXIMATE DIMENSIONS)

- 3 off 20 x 550 x approximately 6 mm hardwood, plywood and glass fibre
- 1 off 19 x 4.5 x 550 mm D-shape brass
- 1 off 13 x 6.4 x 650 mm compound mild steel strut
- 1 off 13 x 13 x 750 mm aluminium channel
- 2 off 13 x 13 x 750 mm aluminium angle (one with special end fittings, giving limited flexibility)
- 1 off 13 x 6.4 x 650 mm rectangular mild steel
- 1 off 6.4 dia x 650 mm mild steel

ESSENTIAL SERVICES

BENCH SPACE NEEDED:

1.5 m x 750 mm

ELECTRICAL SUPPLY:

Single-phase 100 VAC to 240 VAC

50 Hz to 60 Hz with earth

OPERATING CONDITIONS

OPERATING ENVIRONMENT:

Laboratory

STORAGE TEMPERATURE RANGE:

-25°C to +55°C (when packed for transport)

OPERATING TEMPERATURE RANGE:

+5°C to +40°C

OPERATING RELATIVE HUMIDITY RANGE:

80% at temperatures < 31°C decreasing linearly to 50% at 40°C

SOUND LEVELS

Less than 70 dB(A)